

0.145" 4-Character 5 x 7 Dot Matrix Alphanumeric Intelligent Display® Devices with Memory/Decoder/Driver

Lead (Pb) Free Product - RoHS Compliant

DLR1414, DLO1414, DLG1414



Description

The DLR/DLO/DLG1414 is a four digit 5 x 7 dot matrix display module with a built-in CMOS integrated circuit.

The integrated circuit contains memory, ASCII ROM decoder, multiplex circuitry and drivers. Data entry is asynchronous and random. A display system can be built using any number of DLX1414s since each character in any DLX1414 can be addressed independently and will continue to display the character last stored until replaced by another.

System interconnection is very straightforward. The least significant two address bits (A0, A1) are normally connected to the like named inputs of all displays in the system. Data lines are connected to all DLX1414s directly and in parallel as is the write line (\overline{WR}). The display then will behave as a write only memory.

The DLX1414 has several features superior to competitive devices. The character set consists of 128 special ASCII characters for English, German, Italian, Swedish, Danish, and Norwegian.

Features

- 0.145" High, Dot Matrix Character
- 128 Special ASCII Characters for English, German, Italian, Swedish, Danish, and Norwegian Languages
- Wide Viewing Angle: X Axis $\pm 50^\circ$, Y Axis $\pm 75^\circ$
- Close Vertical Row Spacing, 0.800" Centers
- Fast Access Time, 110 ns at 25°C
- Compact Size for Hand Held Equipment
- Built-in Memory
- Built-in Character Generator
- Built-in Multiplex and LED Drive Circuitry
- Direct Access to Each Digit Independently and Asynchronously
- TTL Compatible, 5.0 Volt Power
- Low Power Consumption, 20 mA per Character Typical
- Intensity Coded for Display Uniformity
- Extended Operating Temperature Range: -40°C to $+85^\circ\text{C}$
- End Stackable, 4-Character Package

See Appnotes 18, 19, 22, and 23 for additional information.

Ordering Information

Type	Color of Emission	Ordering Code
DLR1414	red	Q68000A8091
DLO1414	high efficiency red	Q68000A8092
DLG1414	green	Q68000A8093

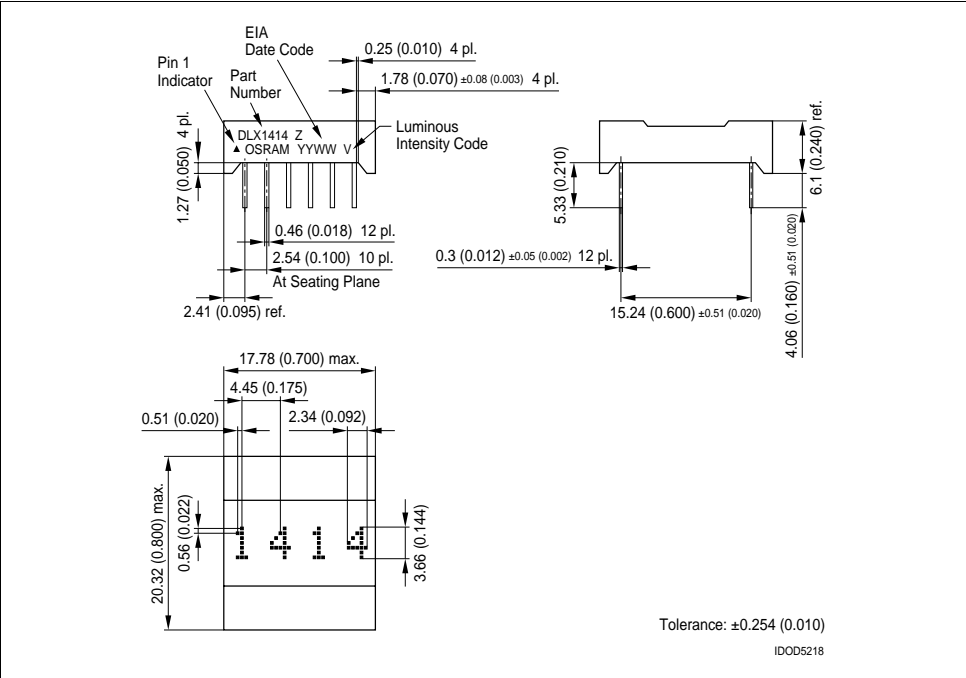

Maximum Ratings

Parameter	Symbol	Value	Unit
Operating temperature range	T_{op}	- 40 ... + 85	°C
Storage temperature range	T_{stg}	- 40 ... + 100	°C
DC supply voltage		- 0.5 ... + 7.0	V
Input voltage levels relative to GND (all inputs)		- 0.5 to $V_{CC} + 0.5$	V
Solder temperature 0.063" (1.59 mm) below seating plane, $t < 5.0$ s	T_s	260	°C
Relative humidity at 85°C	RH	85	%

Characteristics $(T_A = 25\text{ °C})$

Parameter	Symbol	Values			Unit
		DLR1414	DLO1414	DLG1414	
		red	high efficiency red	green	
Wavelength at peak emission $I_F = 0$ mA (typ.)	λ_{peak}	660	630	565	nm
Viewing angle (off normal axis), hor. (typ.) ver. (typ.)	2φ	± 50 ± 75	± 50 ± 75	± 50 ± 75	deg deg.
Character Height	h	0.145 3.7	0.145 3.7	0.145 3.7	inch mm
Time averaged luminous intensity ¹⁾ (100% brightness, $V_{CC} = 5.0$ V) (typ.)		50	60	70	$\mu\text{cd}/\text{LED}$
LED to LED intensity matching (max.)		1.8:1.0	1.8:1.0	1.8:1.0	
LED to LED hue matching at $V_{CC} = 5.0$ V (max.)				± 2.0	nm

¹⁾ Peak luminous intensity values can be calculated by multiplying these values by 7.

Top View

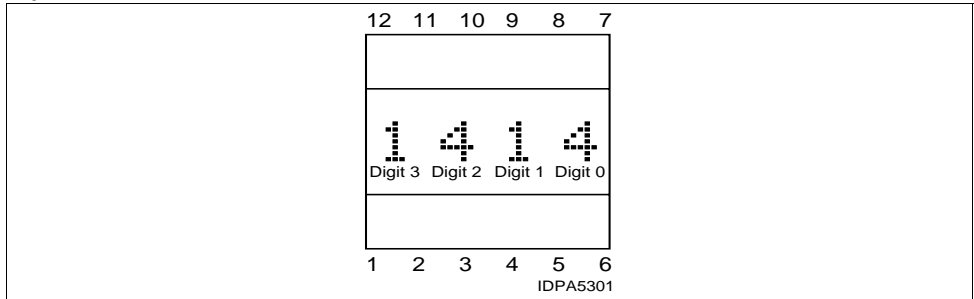

DC Characteristics

Parameter	-40°C			+25°C			+85°C			Unit	Condition
	Min.	Typ.	Max.	Min.	Typ.	Max.	Min.	Typ.	Max.		
I_{CC} 4 Digits on 20 dots/digit	—	90	120	—	80	105	—	70	95	mA	$V_{CC}=5.0\text{ V}$
I_{CC} Blank	—	2.8	4.0	—	2.3	3.0	—	2.0	2.5	mA	$V_{CC}=5.0\text{ V}$, $\overline{WR}=5.0\text{ V}$ $V_{IN}=0\text{ V}$
I_{IL} (all inputs)	30	60	120	25	50	100	20	40	80	μA	$V_{IN}=0.8\text{ V}$, $V_{CC}=5.0\text{ V}$
V_{IH}	2.0	—	—	2.0	—	—	2.0	—	—	V	$V_{CC}=5.0\text{ V}$ $\pm 0.5\text{ V}$
V_{IL}	—	—	0.8	—	—	0.8	—	—	0.8	V	$V_{CC}=5.0\text{ V}$ $\pm 0.5\text{ V}$
V_{CC}	4.5	5.0	5.5	4.5	5.0	5.5	4.5	5.0	5.5	V	—

Pins and Functions

Pin	Function	Pin	Function	Pin	Function
1	D5 Data Input	5	A0 Digit Select	9	D1 Data Input
2	D4 Data Input	6	V_{CC}	10	D2 Data Input
3	\overline{WR} Write	7	GND	11	D3 Data Input
4	A1 Digit Select	8	D0 Data Input (LSB)	12	D6 Data Input (MSB)

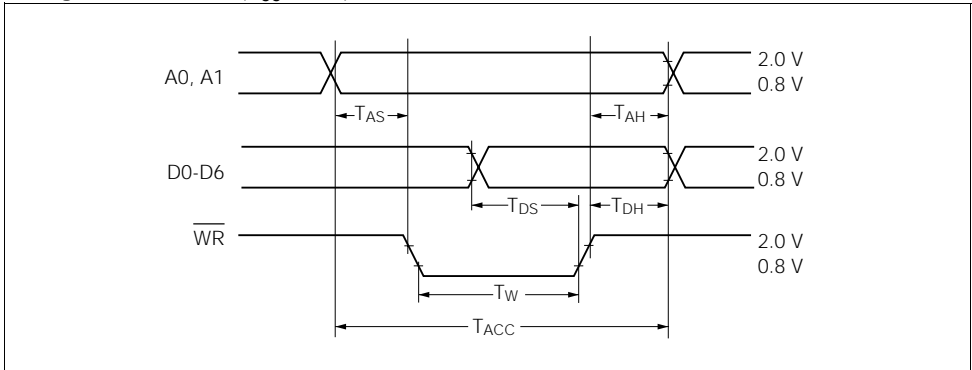
Timing Characteristics ($V_{CC}=4.5\text{ V}$)

Note: These waveforms are not edge triggered.

AC Characteristics (guaranteed minimum timing parameters at $V_{CC}=5.0\text{ V} \pm 0.5\text{ V}$)

Parameter	Symbol	-40°C	+25°C	+85°C	Unit
Address Set Up Time	T_{AS}	10	10	10	ns
Address Hold Time	T_{AH}	20	30	40	ns
Write Time	T_W	60	70	90	ns
Data Set Up Time	T_{DS}	20	30	50	ns
Data Hold Time	T_{DH}	20	30	40	ns
Access Time ¹⁾	T_{ACC}	90	110	140	ns

¹⁾ $T_{ACC} = \text{Set Up Time} + \text{Write Time} + \text{Hold Time}$.

Loading Data State Table

\overline{WR}	A1	A0	D6	D5	D4	D3	D2	D1	D0	Display Digit			
										3	2	1	0
H	previously loaded display									G	R	E	Y
L	L	L	H	L	L	L	H	L	H	G	R	E	E
L	L	H	H	L	H	L	H	L	H	G	R	U	E
L	H	L	H	L	L	H	H	L	L	G	L	U	E
L	H	H	H	L	L	L	L	H	L	B	L	U	E
L	L	H	H	L	L	H	H	L	H	B	L	E	E
L	L	L	H	L	H	L	H	H	H	B	L	E	W
L	X	X	see character code							see character set			

X=Don't care

Typical Interconnection for 32 Characters

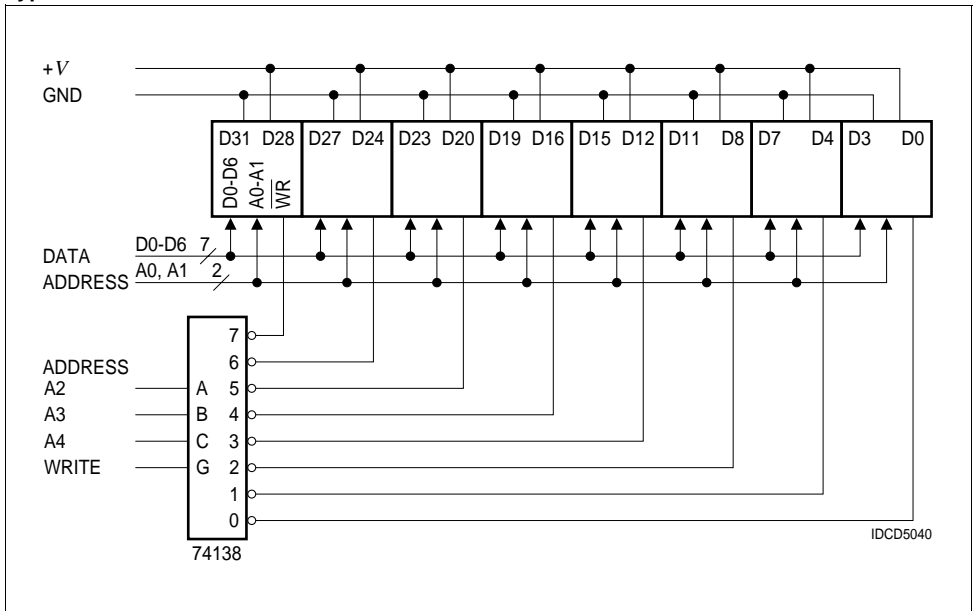

Block Diagram

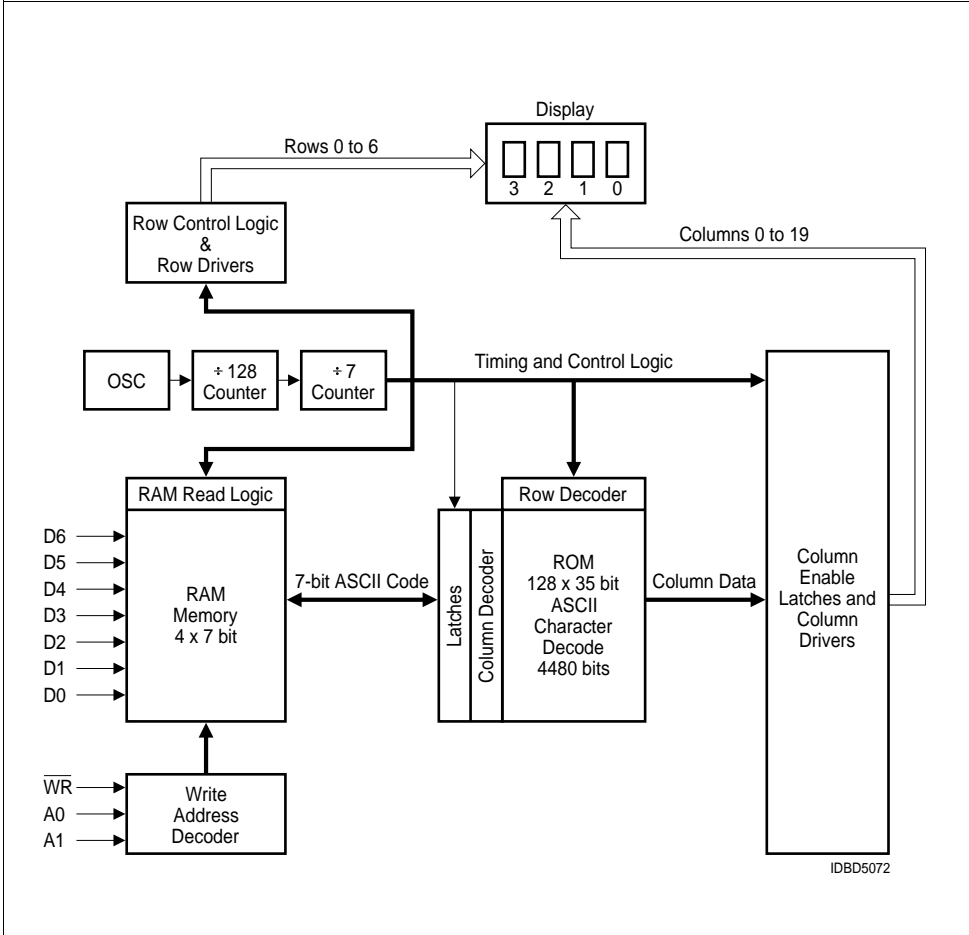

Character Set

ASCII CODE				D0	0	1	0	1	0	1	0	1	0	1	0	1	0	1		
				D1	0	0	1	1	0	0	1	1	0	0	1	1	0	0	1	1
				D2	0	0	0	0	0	1	1	1	1	0	0	0	0	1	1	1
				D3	0	0	0	0	0	0	0	0	1	1	1	1	1	1	1	1
D6	D5	D4	HEX	0	1	2	3	4	5	6	7	8	9	A	B	C	D	E	F	
0	0	0	0	0	1	2	3	4	5	6	7	8	9	A	B	C	D	E	F	
0	0	1	1	0	1	2	3	4	5	6	7	8	9	A	B	C	D	E	F	
0	1	0	2	0	1	2	3	4	5	6	7	8	9	A	B	C	D	E	F	
0	1	1	3	0	1	2	3	4	5	6	7	8	9	A	B	C	D	E	F	
1	0	0	4	0	1	2	3	4	5	6	7	8	9	A	B	C	D	E	F	
1	0	1	5	0	1	2	3	4	5	6	7	8	9	A	B	C	D	E	F	
1	1	0	6	0	1	2	3	4	5	6	7	8	9	A	B	C	D	E	F	
1	1	1	7	0	1	2	3	4	5	6	7	8	9	A	B	C	D	E	F	

IDCS5087

Notes:

1. High=1 level
2. Low=0 level
3. Upon power up, the device will initialize in a random state.

Revision History: 2006-01-23

Previous Version: 2004-11-04

Page	Subjects (major changes since last revision)	Date of change
all	completely rework	2004-08-31
all	Lead free device	2006-01-23

Attention please!

The information describes the type of component and shall not be considered as assured characteristics. Terms of delivery and rights to change design reserved. Due to technical requirements components may contain dangerous substances. For information on the types in question please contact our Sales Organization. If printed or downloaded, please find the latest version in the Internet.

Packing

Please use the recycling operators known to you. We can also help you – get in touch with your nearest sales office. By agreement we will take packing material back, if it is sorted. You must bear the costs of transport. For packing material that is returned to us unsorted or which we are not obliged to accept, we shall have to invoice you for any costs incurred.

Components used in life-support devices or systems must be expressly authorized for such purpose! Critical components¹⁾ may only be used in life-support devices or systems²⁾ with the express written approval of OSRAM OS.

¹⁾ A critical component is a component used in a life-support device or system whose failure can reasonably be expected to cause the failure of that life-support device or system, or to affect its safety or the effectiveness of that device or system.

²⁾ Life support devices or systems are intended (a) to be implanted in the human body, or (b) to support and/or maintain and sustain human life. If they fail, it is reasonable to assume that the health and the life of the user may be endangered.

Design Considerations

For details on design and applications of the DLX1414 using standard bus configurations in multiple display systems, or parallel I/O devices, such as the 8255 with an 8080 or memory mapped addressing on processors such as the 8080, Z80, 6502, 8748, or 6800, refer to Appnote 15 at www.osram-os.com.

Electrical & Mechanical Considerations

Voltage Transient Suppression

We strongly recommend that the same power supply be used for the display and the components that interface with the display to avoid logic inputs higher than V_{CC} . Additionally, the LEDs may cause transients in the power supply line while they change display states. The common practice is to place .01 mF capacitors close to the displays across V_{CC} and GND, one for each display, and one 10 mF capacitor for every second display.

ESD Protection

The metal gate CMOS IC of the DLX1414 is extremely immune to ESD damage. However, users of these devices are encouraged to take all the standard precautions, normal for CMOS components. These include properly grounding personnel, tools, tables, and transport carriers that come in contact with unshielded parts. Where these conditions are not, or cannot be met, keep the leads of the device shorted together or the parts in anti-static packaging.

Soldering Considerations

The DLX1414 can be hand soldered with SN63 solder using a grounded iron set to 260°C.

Wave soldering is also possible following these conditions: Preheat that does not exceed 93°C on the solder side of the PC board or a package surface temperature of 85°C. Water soluble organic acid flux (except carboxylic acid) or rosin-based RMA flux without alcohol can be used.

Wave temperature of 245°C \pm 5°C with a dwell between 1.5 sec. to 3.0 sec. Exposure to the wave should not exceed temperatures above 260°C for five seconds at 0.063" below the seating plane. The packages should not be immersed in the wave.

Post Solder Cleaning Procedures

The least offensive cleaning solution is hot D.I. water (60°C) for less than 15 minutes. Addition of mild saponifiers is acceptable. Do not use commercial dishwasher detergents.

For faster cleaning, solvents may be used. Carefully select solvents as some may chemically attack the nylon package. Maximum exposure should not exceed two minutes at elevated temperatures. Acceptable solvents are TF (trichlorotrifluoroethane), TA, 111 Trichloroethane, and unheated acetone.

Note: Acceptable commercial solvents are: Basic TF, Arklone P, Genesolve D, Blaco-tron TF, Genesolve DA, and Blaco-tron TA. Unacceptable solvents contain alcohol, methanol, methylene chloride, ethanol, TP35, TCM, TMC, TMS+, TE, or TES. Since many commercial mixtures exist, contact a solvent vendor for chemical composition information. Some major solvent manufacturers are: Allied Chemical Corporation, Specialty Chemical Division, Morristown, NJ; Baron-Blakeslee, Chicago, IL; Dow Chemical, Midland, MI; E.I. DuPont de Nemours & Co., Wilmington, DE. For further information refer to Appnotes 18 and 19 at www.osram-os.com.

An alternative to soldering and cleaning the display modules is to use sockets. Eighteen pin DIP sockets .600" wide with .100" centers work well for single displays. Multiple display assemblies are best handled by longer SIP sockets or DIP sockets when available for uniform package alignment. Socket manufacturers are Aries

Electronics, Inc., Frenchtown, NJ; Garry Manufacturing, New Brunswick, NJ; Robinson-Nugent, New Albany, IN; and Samtec Electronic Hardware, New Albany, IN.

For further information refer to Appnote 22 at www.osram-os.com.

Optical Considerations

The .145" high characters of the DLX1414 gives readability up to eight feet. The user can build a display that enhances readability over this distance by proper filter selection.

Using filters emphasizes the contrast ratio between a lit LED and the character background. This will increase the discrimination of different characters. The only limitation is cost. Remember to take into consideration the ambient lighting environment for the best cost/benefit ratio for filters.

Incandescent (with almost no green) or fluorescent (with almost no red) lights do not have the flat spectral response of sunlight. Plastic band-pass filters are an inexpensive and effective way to strengthen contrast ratios. The DLR1414 is a standard red display and should be matched with long wavelength pass filter in the 600 nm to 620 nm range. For displays of multiple colors, neutral density grey filters offer the best compromise.

The DLO1414 is a high efficiency red display and should be matched with a long wavelength pass filter in the 570 nm to 590 nm range. The DLG1414 should be matched with a yellow-green band-pass filter that peaks at 565 nm. For displays of multiple colors, neutral density gray filters offer the best compromise.

Additional contrast enhancement can be gained by shading the displays. Plastic band-pass filters with built-in louvers offer the next step up in contrast improvement. Plastic filters can be improved further with anti-reflective coatings to reduce glare. The trade-off is fuzzy characters. Mounting the filters close to the display reduces this effect. Take care not to overheat the plastic filter by allowing for proper air flow.

Optimal filter enhancements are gained by using circular polarized, anti-reflective, band-pass filters. The circular polarizing further enhances contrast by reducing the light that travels through the filter and reflects back off the display to less than 1%. Several filter manufacturers supply quality filter materials. Some of them are: PanelGraphic Corporation, W. Caldwell, NJ; SGL Homa-lite, Wilmington, DE; 3M Company, Visual Products Division, St. Paul, MN; Polaroid Corporation, Polarizer Division, Cambridge, MA; Marks Polarizer Corporation, Deer Park, NY; Hoya Optics, Inc., Fremont, CA.

One last note on mounting filters: recessing displays and bezel assemblies is an inexpensive way to provide a shading effect in overhead lighting situations. Several bezel manufacturers are: R.M.F. Products, Batavia, IL; Nobex Components, Griffith Plastic Corp., Burlingame, CA; Photo Chemical Products of California, Santa Monica, CA; I.E.E.-Atlas, Van Nuys, CA. Refer to Appnote 23 at www.osram-os.com.

Published by
OSRAM Opto Semiconductors GmbH
Wernerwerkstrasse 2, D-93049 Regensburg
www.osram-os.com
© All Rights Reserved.